

ASSEMBLY INSTRUCTIONS FOR RAM ANGLE FRAMED CONSOLE

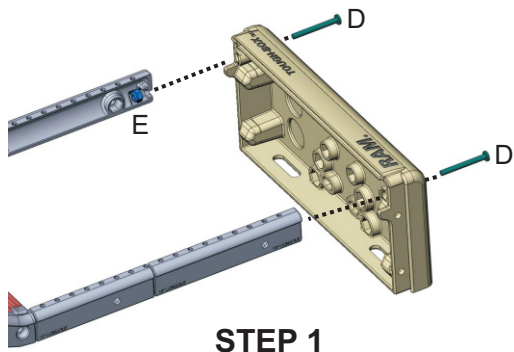

STEP 1

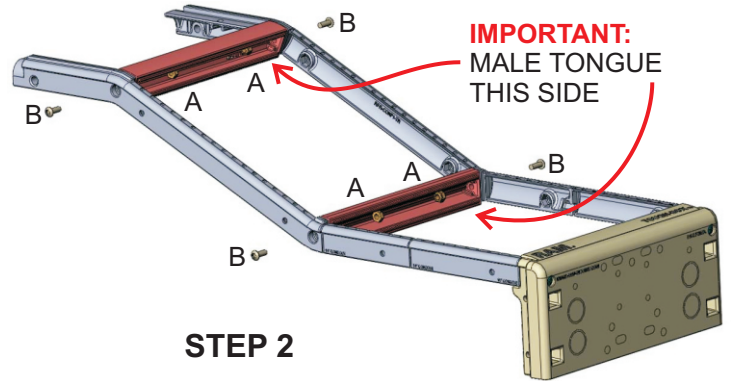

STEP 2

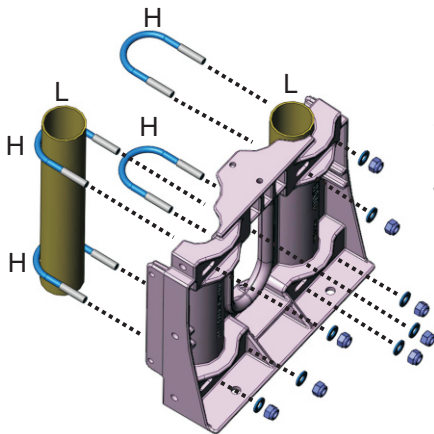

STEP 3 IS OPTIONAL TELE-POLE KIT

- H: 4 QTY. U-BOLTS
- J: 8 QTY. 1/4"-20 NYLOCK HEX NUTS
- K: 8 QTY. 1/4" FLAT WASHERS
- L: 2 QTY. STEEL TELE-POLE TUBES
- M: 2 QTY. TELE-POLE RUBBER CAPS

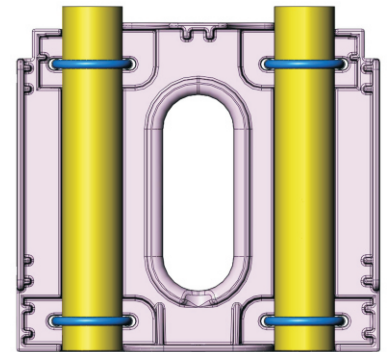

NOTE: TUBES MUST NOT PROTRUDE FROM BOTTOM OF PLASTIC FRAME

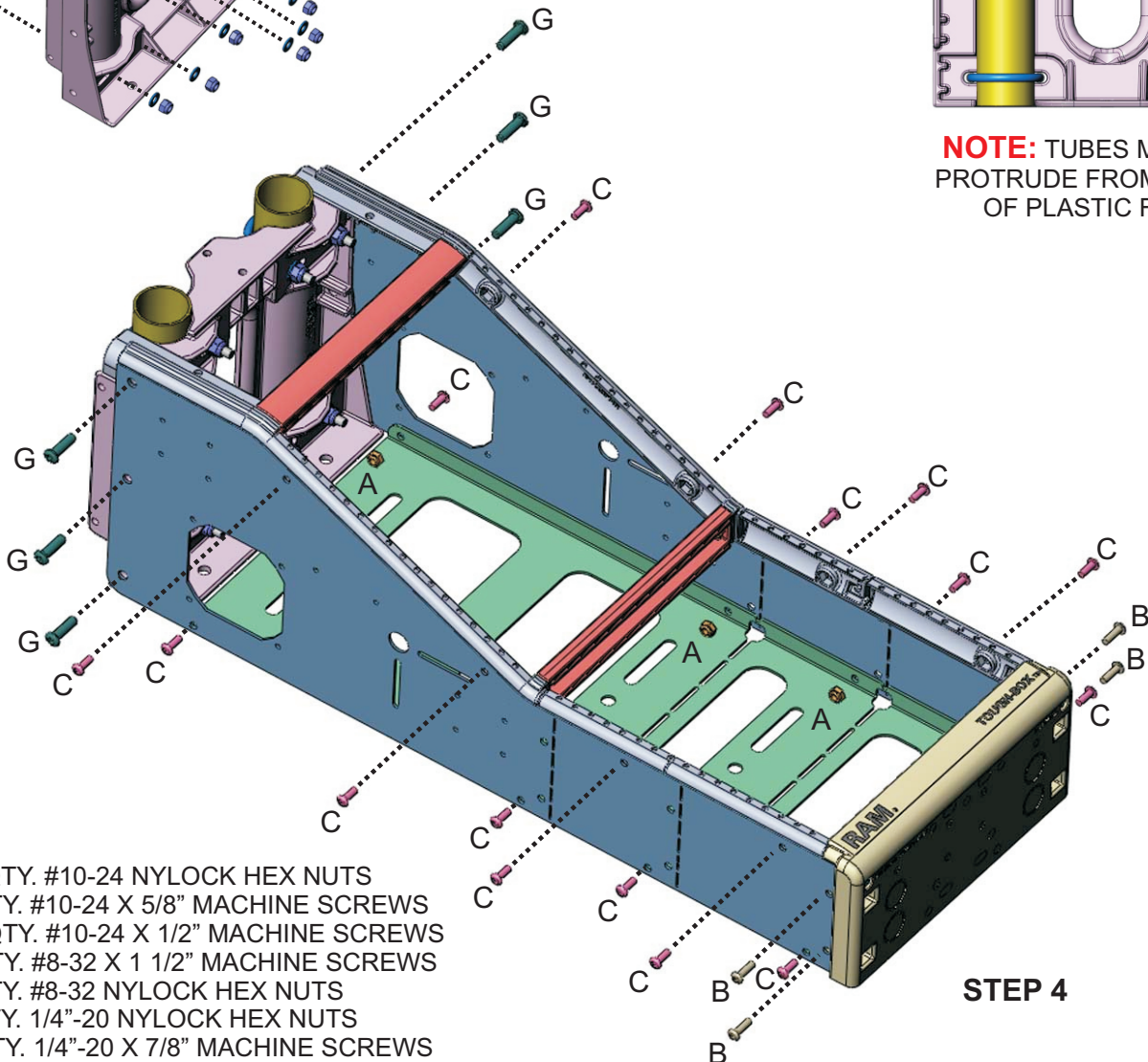

STEP 4

- A: 32 QTY. #10-24 NYLOCK HEX NUTS
- B: 8 QTY. #10-24 X 5/8" MACHINE SCREWS
- C: 24 QTY. #10-24 X 1/2" MACHINE SCREWS
- D: 2 QTY. #8-32 X 1 1/2" MACHINE SCREWS
- E: 2 QTY. #8-32 NYLOCK HEX NUTS
- F: 6 QTY. 1/4"-20 NYLOCK HEX NUTS
- G: 6 QTY. 1/4"-20 X 7/8" MACHINE SCREWS

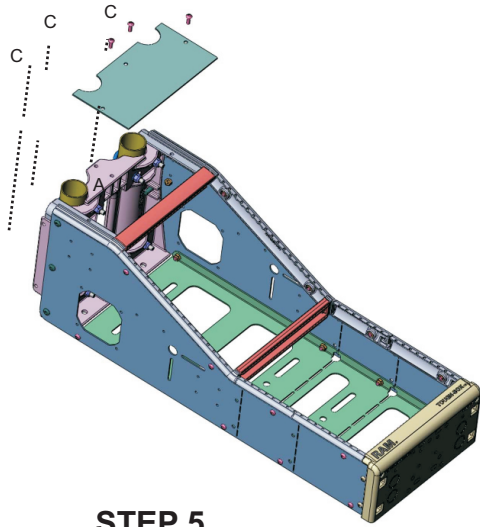

STEP 5

**SHOWN WITH OPTIONAL:
FACEPLATES, FRONT TRIM & TELE-POLES**

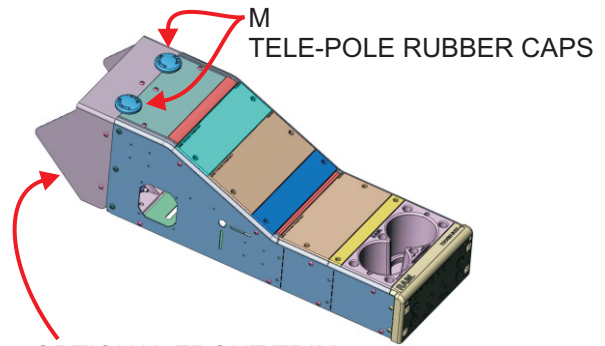

**OPTIONAL FRONT TRIM
VEHICLE SPECIFIC**

STEP 6

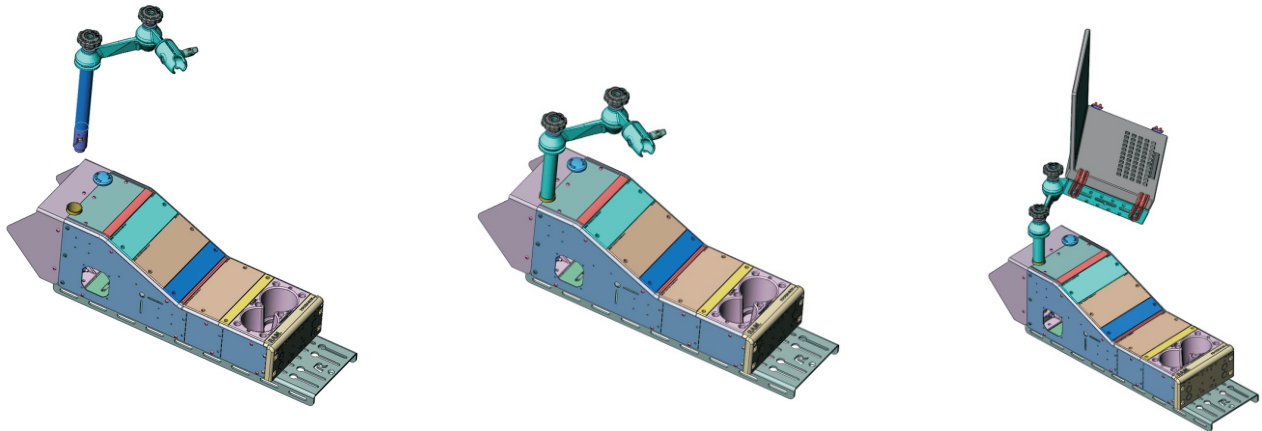

1. Attach the rear end cap to the side rails as shown in step 1 using screw D and nut E.
2. Attach cross bars at the bends using screw B and nut A. Make sure to orient the cross bars so that the tongue is toward the rear of the console box.
3. If using the optional Tele-Pole kit, refer to the drawing in step 3 for attaching the steel tubes to the plastic frame.
4. Take the sections of the console box assembled in step 1, 2, and 3 and join them by attaching the side plates as shown in step 4. Be sure to refer to the drawing and select the size hardware for each section of the console side panels.
5. Using screw C and nut A, secure the upper most top plate to the console box as shown.
6. Step 6 depicts options such as filler plates, tube caps. Refer to the instruction sheets that accompany these products to aide in their installation.
7. Place the fan cover over the square opening and secure using 4 quantity of the #10 sheet metal screws. Secure these even if you do not plan to use the optional fan as these covers prevent large debris from entering the console box.

National Products Inc. 8410 Dallas Ave. S. Seattle, WA 98108
 Phone: (206) 763-8361 Fax: (206) 763-9615
 Web: www.ram-mount.com E-mail: staff@ram-mount.com